



**60**  
YEARS  
*Providing Solutions  
for the Pharmaceutical Industry.*

# PICCOLA CLASSICA®

Table rotary tablet press ideal for research and development



The PICCOLA CLASSICA is a rotary tablet press intended for implementation in the research and development area, and it is designed for pilot plants and/or small production batches. Its settings allow operating with one to ten sets of punches placed in the turret head. Punches and dies conform to the international TSM or EU (B/D) standards.

Among its main characteristics, it features a gravity or forced-load feed system, a pre-compression system, quick format change, and easy cleaning and sterilization. It is also designed under GMP guidelines with surfaces machined with hard chrome and AISI 316 stainless steel.

With over 60 years of expertise and over 600 Piccolas sold worldwide, Riva S.A. has evolved to meet the varied and strict client needs, maintaining durability and reliability.

Technical Data	D-8	B-10	BD 4+4
Standard	TSM / EU		
Maximum tablet diameter	24mm	16mm	16-24mm
Maximum load depth	19mm		
Maximum final compression force	60kN		
Maximum 1st compression force	3kN		
Tablets per hour output	24.000 T/H	30.000 T/H	12.000 T/H
Upper punch penetration	2-8mm		
Product feed	Gravity / Forced		
Power installed	2kW		
Die bore diameter	150mm		
Net weight	300kg		

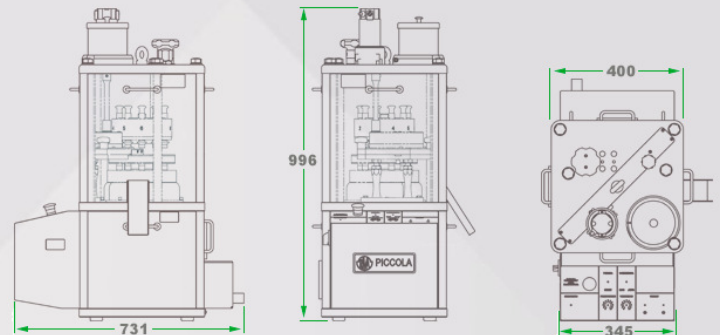

RIVA S.A. GÉNOVA 4018 - CIUDADELA, B1702CQH - BUENOS AIRES, ARGENTINA  
TEL.: +54 11 4653-2000 WWW.RIVASA.COM INFO@RIVASA.COM

