



60
YEARS
*Providing Solutions
for the Pharmaceutical Industry.*

MINIPRESS MII®

Maximum quality single-punch tablet press



This eccentric table single-punch tablet press is the smallest press in our machine family. Developed for the production of small batches and galenic research and development works for small batches, it features a dosage adjustment system for tablet weight control, a speed drive, and, optionally, a tablet hardness control system during the compression stage.

The gearbox is assembled on a cabinet separated from the compression zone. Its quick and versatile tooling change mechanism is to be highlighted, and it is fully designed under GMP standards with hard chrome and AISI 316 stainless steel machined surfaces, forming a solid, precise and reliable machine.

With over 60 years of expertise and over 400 Minipress MII sold worldwide, Riva S.A. has evolved to meet the varied and strict client needs, always maintaining its durability and reliability.

Technical Data

Standard	No standard / special
Maximum tablet diameter	24mm
Maximum load depth	19mm
Maximum final compression force	60kN
Power installed	1.85kW
Tablets per hour output	6000 T/H
Upper punch penetration	3-14mm
Product feed	Gravity
Net weight	280kg

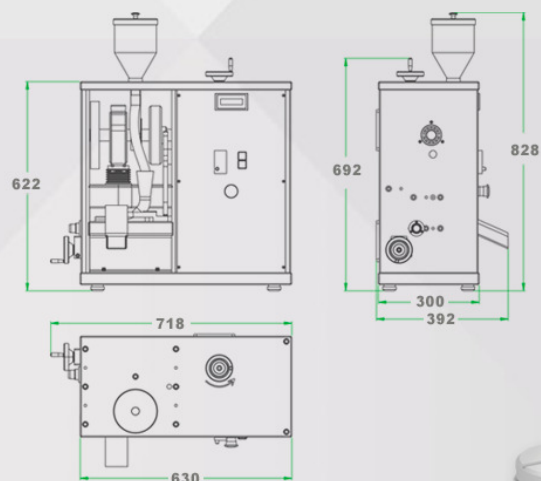

RIVA S.A. GÉNOVA 4018 - CIUDADELA, B1702CQH - BUENOS AIRES, ARGENTINA
TEL.: +54 11 4653-2000 WWW.RIVASA.COM INFO@RIVASA.COM

